



www.emrwebsite.org

**“Modelling and control using
ENERGETIC MACROSCOPIC REPRESENTATION”**
Application to hybrid electric vehicles and others

14-17 June 2021

Lille, France



EMR'06 (France)



EMR'08 (China)



EMR'09 (Canada)



EMR'11 (Switzerland)



EMR'12 (Spain)



EMR'16 (Canada)

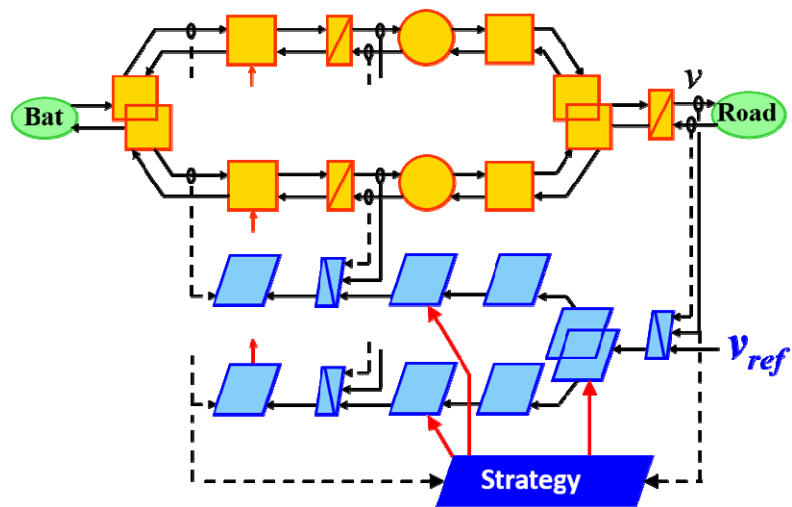

EMR of an Electric Vehicle



EMR'13 (France)



EMR'14 (Portugal)



EMR'15 (France)



EMR'17 (France)



EMR'18 (Vietnam)



EMR'19 (France)

SUPPORTS



OBJECTIVE

This workshop is focused on the **Energetic Macroscopic Representation (EMR)** methodology for modelling and control of complex electromechanical systems.

This Summer School is aimed at Master and PhD students, Engineers and scientists, from both academia and industry, who have to **model and control new multi-physical systems** such as industrial multi-drive systems, traction and propulsion systems, hybrid electric vehicles, or renewable energy generation systems.

EMR is a graphical formalism that was introduced in 2000 to describe complex electromechanical systems. EMR has since been extended to complex multi-physical systems (thermal science, electrochemistry, fluid mechanics ...). EMR is based on the action-reaction principle to organize the interconnection of models of sub-systems according to the physical causality (i.e. integral causality). This description highlights energetic properties of the system (energy accumulation, conversion and distribution). Moreover, an **inversion-based control** can be systematically deduced from EMR using specific inversion rules.

Compared with other graphical description, such as Bond Graphs or Causal Ordering Graphs (COG), EMR has a more global energetic view and contributes to system's control design. It differs from structural description tools such as Physic Modelling Language (PML) using Object-Oriented Modelling Language, which makes its libraries to be coupled in the same way as physical units. EMR is focused on the system function and not only on the system structure. EMR gives insights into the real energy operation of systems and allows a deep understanding of its potentialities from a dynamic point of view.

In short, the distinct features of EMR lie in its clarity of physical concepts, as well as their physical causality, and its functional description rather than a structural description. It hence contributes significantly to the design of control and energy management of systems.

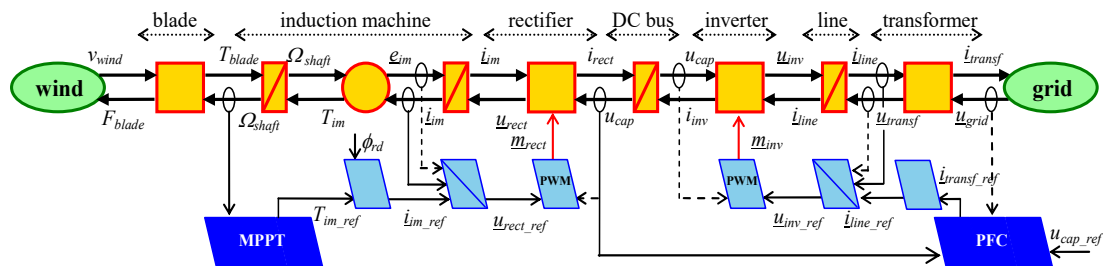

Energetic Macroscopic Representation of a Wind Energy Conversion System

PREVIOUS EMR SUMMER SCHOOLS



EMR'18, June 2018, Hanoi, Vietnam



EMR'17, June 2019, Lille, France

- EMR'06 - Lille (France) / EMR'08 - Harbin (China),
 EMR'09 - Trois-Rivières (Canada) / EMR'11 - Lausanne (Switzerland),
 EMR'12 - Madrid (Spain) / EMR'13 - Lille (France),
 EMR'14 - Coimbra (Portugal) / EMR'15 - Lille (France),
 EMR'16 - Montreal (Canada) / EMR'17 - Lille (France)
 EMR'18 - Hanoi (Vietnam) / EMR'19 - Lille (France)
 EMR'20 (Ovideo, Spain) has been cancelled due to COVID-19 crisis*

SIMULATION TRAINING SESSION

The aim of this Summer School is to **give a first-hand experience in practice of using EMR and inversion-based control**. Three afternoons will be dedicated to simulation training sessions using MATLAB®-Simulink®. Attendees will simulate a complete system and its control using EMR methodology. They will choose to study an electric vehicle, a photovoltaic system or a wind energy conversion system. An EMR library will be provided to all attendees.

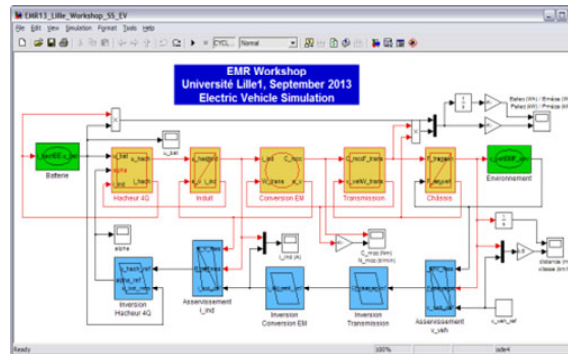

*MATLAB®-Simulink® model of an Electric Vehicle (orange)
and its control (blue) derived from EMR*

PROVISIONAL SCHEDULE

As EMR'21 will be hybrid, a specific schedule has been developed for worldwide on-line attendance for the lectures and cloud-based simulation with the support of the H2020 PANDA project.

— Monday 14 June 2021 —

14:00 – 17:00 (CET): Lectures on fundamentals on EMR and inversion-based control, basic examples

— Tuesday 15 June 2021 —

9:00 – 12:00 (CET): Simulation training session (part I), modelling of the considered system

14:00 – 17:00 (CET): Lectures on applications to complex systems (part I)

(Hybrid Electric Vehicles, Automatic subway traction systems, Fuel Cell systems...)

— Wednesday 16 June 2021 —

9:00 – 12:00(CET): Simulation training session (part II), control of the considered system

14:00 – 17:00 (CET): Lectures on applications to complex systems (part II)

(wind energy conversion systems, PV systems, Piezoelectric actuators, multiphase drives...)

— Thursday 17 June 2021 —

9:00 – 12:00 (CET): Simulation training session (part II), energy management of the considered system

14:00 – 17:00 (CET): Lectures on applications to complex systems (part III)

(software engineering and PANDA H2020 simulation and testing)

The full program will be available at <http://www.emrwebsite.org/>

LANGUAGEI

Lectures will be presented in English.
The training sessions will be taught in English and French.

WORKSHOP ORGANIZATION

This workshop is co-organized by the University of Lille (France).

General chair and co-chair

Prof. **Betty LEMAIRE-SEMAIL** (University of Lille, L2EP, France)

Prof. Alain BOUSCAYROL (University of Lille, L2EP, IEEE-VTS, MEGEVH, France)

Coordination committee

Dr. Ngac-Ky NGUYEN (ENSAM, L2EP, France)

Dr VO Duy Thanh (Hanoi University of Sciences and Technology, IEEE-VTS, Vietnam)

EMR International Scientific Committee

Chair: Prof. **Alain BOUSCAYROL** (University of Lille, L2EP, IEEE-VTS, MEGEVH, France)

Prof. Pablo ARBOLEYA (University of Oviedo, LEMUR, IEEE-VTS, Spain)

Dr. Philippe BARRADE (University of Applied Sciences of Sion, IEEE-VTS Switzerland)

Prof. Loïc BOULON (Université du Québec à Trois-Rivières, IRH, IEEE-VTS, Canada)

Prof. Daniel HISSEL (University of Franche Comté, FEMTO-ST, IEEE-VTS, MEGEVH, France)

Prof. Eric HITTINGER (Rochester Institute of Technology USA)

Prof. Betty LEMAIRE-SEMAIL (University of Lille, L2EP, France)

Dr. Clément MAYET (Le CNAM, SATIE, IEEE-VTS, France)

Dr. Daniel MONTESINOS (Universitat Politècnica de Catalunya, Spain)

Prof. Paulo PEREIRINHA (Polytechnic Institute of Coimbra, INESC Coimbra, IEEE-VTS, Portugal)

Dr. TA Cao Minh (Hanoi University of Sciences and Technology, IEEE-VTS, Vietnam)

Prof. João Pedro TROVÃO (Université de Sherbrooke, e-TESC Lab., IEEE-VTS, Canada)

REGISTRATION

Due to the simulation training session, the number of attendees is limited to 50. A registration form is required. The registration fees include on-line access to lectures and to cloud-based simulation. Registration will open in May 2021.

	Before June 10th
Students	75 €
Academic	105 €
Industrial	175 €

An attendance certification will be provided for French students (Doctoral Schools) and students from other countries (3 equivalent ECTS in Europe for example). For other education systems an attendance certificate will provide the detail of courses with lesson and practical works hours.

INFORMATION

Contact: Betty.Semail@univ-lille.fr

The summer school takes place in the « cité scientifique » campus of University of Lille 59655 Villeneuve d'Ascq France, Subway station " 4 cantons" (Line 1) and also on-line.

More information: <http://www.emrwebsite.org/>