

INTERNATIONAL SUMMER SCHOOL - EMR'26

Modena (Italy), July 1 – 3, 2026 (both in presence and online)

<https://emr-website.univ-lille.fr/>

co-organized by: “Enzo Ferrari” Department of Engineering, University of Modena and Reggio Emilia (Italy) and L2EP, University of Lille (France)

This workshop is focused on the **Energetic Macroscopic Representation (EMR)** methodology for modelling and control of complex electromechanical systems.

EMR is a graphical formalism that was introduced in 2000 to describe **complex electromechanical systems**. EMR has since been extended to complex **multi-physical systems** (combining thermal science, electrochemistry, fluid mechanics, etc).

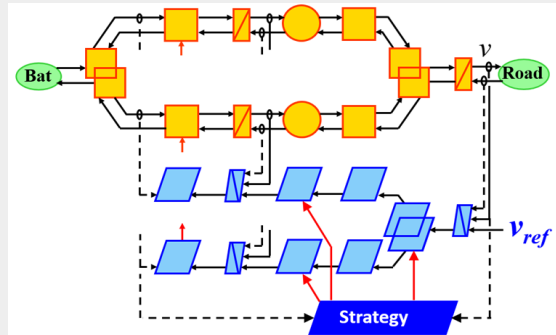

EMR is based on the action-reaction principle to organize the interconnection of models of sub-systems according to the physical causality (i.e. integral causality). **This description highlights energetic properties** of the system (energy accumulation, conversion and distribution). Furthermore, an **inversion-based control** can be systematically deduced from EMR using specific inversion rules.

This Summer School is aimed at **Master and PhD students, Engineers and Scientists**, from both **academia and industry**, who have to model and control new **multi-physical systems such as industrial multi-drive systems, traction and propulsion systems, hybrid electric vehicles, or renewable energy generation systems**.

PROVISIONAL PROGRAMME

Date	Time (CET)	Session
1 st July 2026	14:00 - 17:00	Lecture on fundamentals on EMR and inversion-based control; basic examples
2 nd July 2026	09:00 - 12:00	Simulation training (part I): modelling of the chosen system
	14:00 - 17:00	Lecture on applications to complex systems (part I): Hybrid Electric Vehicles, Automatic subway traction systems, Fuel Cell systems...
3 rd July 2026	09:00 - 12:00	Simulation training (part II): control of the chosen system
	14:00 - 17:00	Lecture on applications to complex systems (part II): Wind energy conversion, PV system, piezoelectrics actuators, multiphase drives...

REGISTRATION

	Before June 21 st	From June 22 nd
Students	50 €	100 €
Academic	150 €	300 €
Industrial	300 €	600 €

WORKSHOP ORGANIZATION

ORGANIZATION ROLES	
<i>Organized by</i>	"Enzo Ferrari" Department of Engineering, UNIMORE
<i>General chair</i>	Dr. Davide TEBALDI University of Modena and Reggio Emilia, Italy
<i>Co-chair</i>	Prof. Alain BOUSCAYROL University of Lille, L2EP, France Prof. Roberto ZANASI University of Modena and Reggio Emilia, Italy
INTERNATIONAL SCIENTIFIC COMMITTEE	
Prof. Alain BOUSCAYROL	Chair of the International Scientific Committee
Dr. Philippe BARRADE	University of Applied Sciences of Sion, IEEE-VTS Switzerland
Prof. Loic BOULON	Universite du Quebec a Trois-Rivieres, IRH, IEEE-VTS, Canada
Prof. Lucia GAUCHIA	University Carlos III of Madrid, IEEE-VTS, Spain
Prof. Christophe GIRAUD-AUDINE	Arts et Metiers Inst. Tech., L2EP, France
Prof. Eric HITTINGER	Rochester Institute of Technology USA, CUMIN
Dr. Halima IKAOUSSEN	University of Franche Comte, FEMTO-ST, MEGEVH, France
Prof. Betty LEMAIRE-SEMAIL	University of Lille, L2EP, France
Dr. Walter LHOMME	University of Lille, L2EP, CUMIN, MEGEVH, France
Dr. Clement MAYET	University of Lille, L2EP, CUMIN, IEEE-VTS, France
Dr. Bedatri MOULIK	Amity University, India
Dr. Bao-Huy NGUYEN	Hanoi University of Sciences and Technology, IEEE-VTS, Vietnam
Prof. Paulo PEREIRINHA	Polytechnic Institute of Coimbra, INESC, IEEE-VTS, Portugal
Dr. Cao Minh TA	Universite de Sherbrooke, IEEE-VTS, Vietnam
Dr. Vo-Duy THANH	Hanoi University of Sciences and Technology, IEEE-VTS, Vietnam
Prof. João Pedro TROVÃO	Université de Sherbrooke, ce -TESC Lab., IEEE-VTS, Canada

PREVIOUS EDITIONS

EMR'06 Lille (France)



EMR'08 Harbin (China)



EMR'09 Trois-Rivières (Canada)



EMR'11 Lausanne (Switzerland)



EMR'12 Madrid (Spain)



EMR'13 Lille (France)



EMR'14 Coimbra (Portugal)



EMR'15 Lille (France)



EMR'16 Montreal (Canada)



EMR'17 Lille (France)



EMR'18 Hanoi (Vietnam)



EMR'19 Lille (France)



EMR'21 Lille (France)



EMR'22 Sion (Switzerland)



EMR'23 Lille (France)



EMR'24 Noida (India)



EMR'25 Lille (France)



We are waiting for you in Modena!

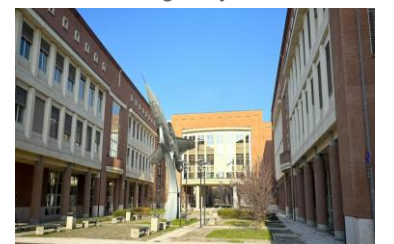

SPONSORED BY

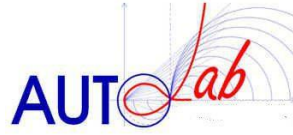

North Jt. Chapter - Italy Section



INFORMATION

Contact davide.tebaldi@unimore.it

More info <https://emrwebsite.org/>

MAP

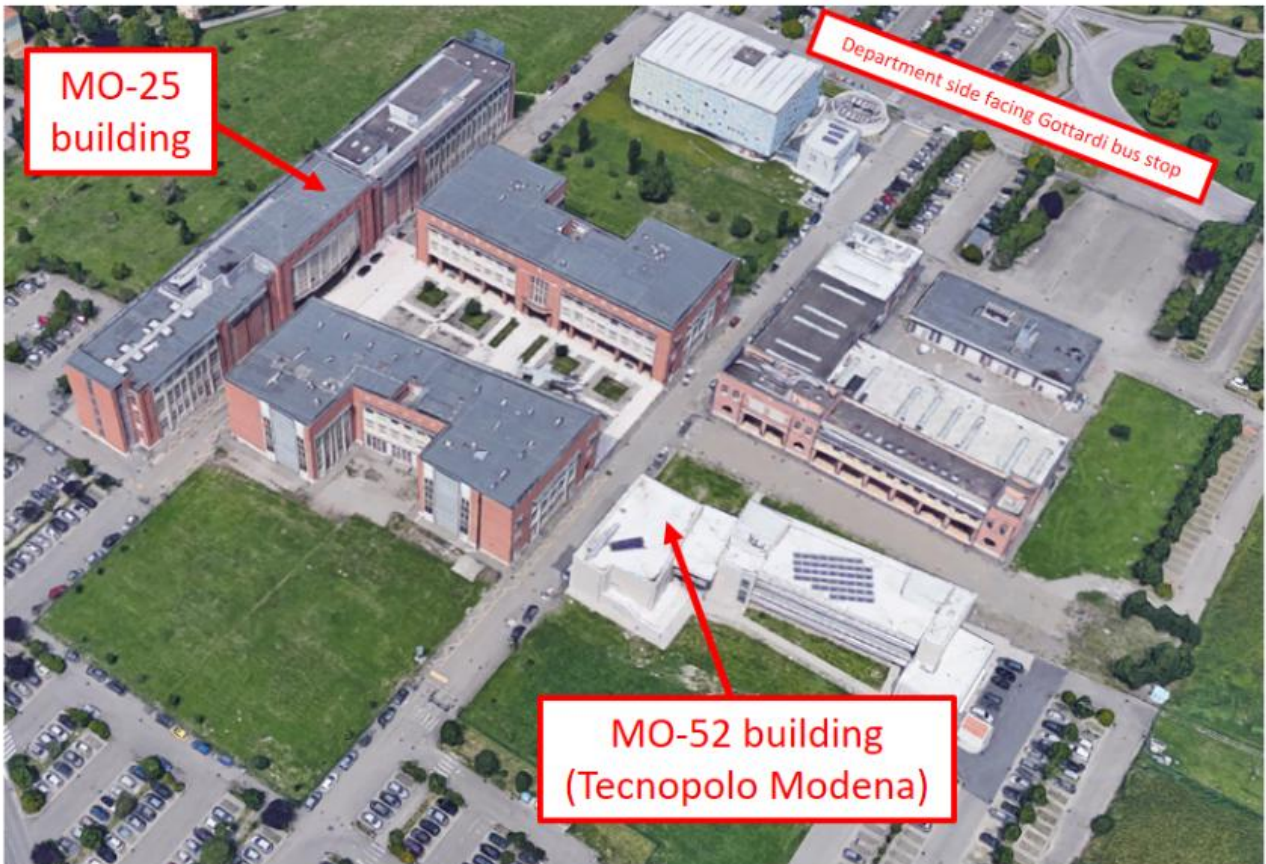

Venue Address: "Enzo Ferrari" Department of Engineering, University of Modena and Reggio Emilia, Via P. Vivarelli, 10, 41125, Modena, Italy